

# SCU Ivian Series Double Shelf Service Counter



## BENEFITS AT A GLANCE

- Deep interior front of the service counter, with a depth of 218mm
- Integrated energy saving lights and overnight blinds as standard
- Tilted bottom bracket and double partitions available as options
- The standard split controller is placed on the deck, convenient for customers to read temperatures and adjust parameters



Standard Model	Double Shelf Service Counter	Double Shelf Corner Service Counter		
	SCU 063/094/125/188/250/375 75 R S DS	SCU EC90 75 R S DS	SCU IC45 75 R S DS	SCU EC45 75 R S DS
Dimensions (Width)	625/937/1250/1875/ 2500/3750	1650	1232	1230
Dimensions (Depth)		1055		1772
Dimensions (Height)		1050		
Operation Temperature (°C)	-1-5	3-8		
Temperature Grade	3 M1	3 S		
Rated Voltage (V)		220V		
Rated Frequency (Hz)		50Hz		
Net Weight (kg)	90/125/160/240/325/490	325	165	165
Display Area (m <sup>2</sup> )	0.49/0.74/0.98/1.47/1.97/2.95	1.28	0.68	0.66
Effective Volume (m <sup>3</sup> )	0.10/0.15/0.20/0.30/0.41/0.61	0.26	0.13	0.125
Energy Efficiency Level (EEL)	Grade 1 *	/		

## CONFIGURATION OPTIONS (STANDARD)

- Crash bar options: aluminum alloy
- Evaporator blower fan options: EBM Q motor\*
- Evaporator Expansion Valve options: Carrier R404A evaporator expansion valve\*
- Double partitions: powder coating

## NOMENCLATURE

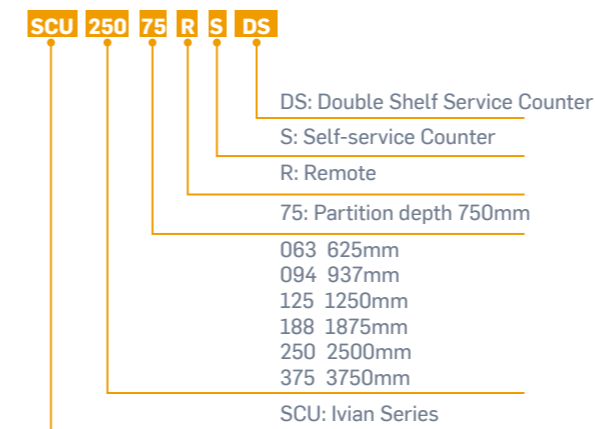

## DIMENSION DRAWING

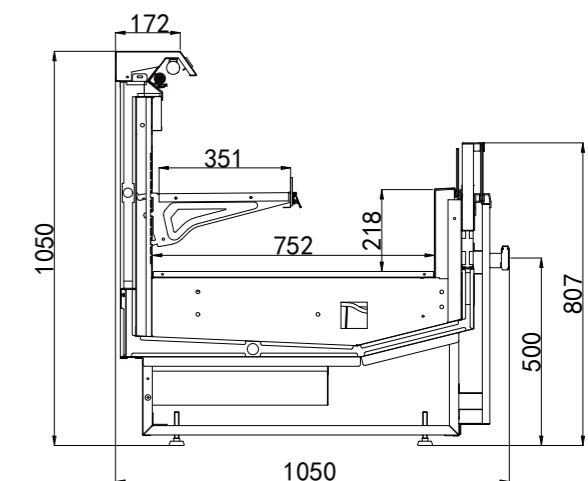

SCU Ivian Series Double Shelf Service Counter

Equivalent brand products can be replaced. For more optional information, please refer to page 63.