

IS-MAX Series Island



BENEFITS AT A GLANCE

- 1.3m Width cabinet design with large size and large capacity for large packaged food
- Dual temperature ranges ensure product quality and operation flexibility, with middle range at $-1\text{--}5^{\circ}\text{C}$ and low range at $-22\text{--}18^{\circ}\text{C}$, adjustable based on operation needs
- Stainless steel design with optional protection bars to match the style of warehouse stores and membership stores

CUSTOMER VALUE

- Larger capacity for more storage, designed for warehouse-style supermarkets and membership stores



Standard Model	IS-MAX Series Island		
	IS Max1813	IS Max2513	IS Max3713
Dimensions (Width)	1875	2500	3750
Dimensions (Depth)	1280		
Dimensions (Height)	990		
Operation Temperature ($^{\circ}\text{C}$)	≤ -18		
Temperature Grade	3 L1		
Rated Voltage (V)	220V		
Rated Frequency (Hz)	50Hz		
Net Weight (kg)	214	285	428
Display Area (m^2)	2.19	2.92	4.38
Effective Volume (m^3)	0.46	0.61	0.91

NOMENCLATURE

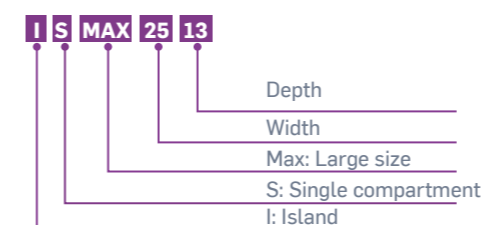

DIMENSION DRAWING

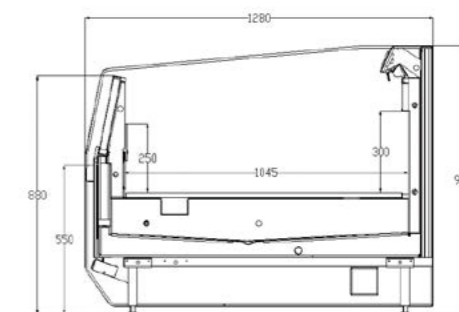

IS-MMAX Series Island