

Hot and Cold Lunch Case



Benefits at a Glance

- All in one (Hot food in winter and cold beverage in summer)
- Optional drawable shelf for quick replenishment
- Saving investment costs and improving the area-effectiveness of the store
- Stylish appearance with stainless steel wrapped edge
- Optimized air curtain and efficient evaporator design to conserve energy and protect environment
- Optional inclined column to expand display area
- Adjustable heating temperature of shelf (0-55°C)
- Hot and cold free switch Adjustable heating and cooling operating mode in every shelf

Standard Configuration

Standard Configuration	CLCR855AH	CLCP855H
Side panel options:	Without side panel	Glass foamed side panel-stainless steel front heads
Shelf configuration	Heating shelf	Heating shelf
Night curtain:	With night curtain	With night curtain
Lunch case expansion valve options	Carrier R404A expansion valve	Carrier R404A expansion valve
Lunch case LED light:	T8 Express, 6500K	T8 Express, 6500K
Evaporator fans option:	Match-Well fan	Match-Well fan
Power cords options:	/	Power cord-with circuit breakers
Hole cover color option:	/	White hole cover
Front end return air grilles:	Stainless steel	Stainless steel

Naming Rules

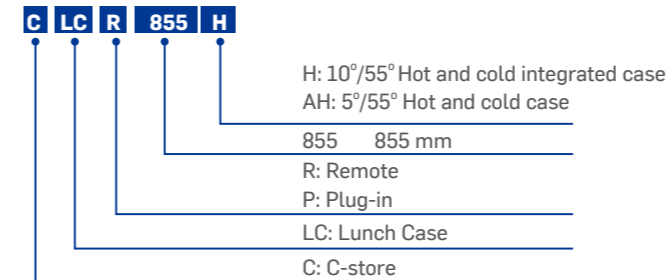

Dimension Drawing

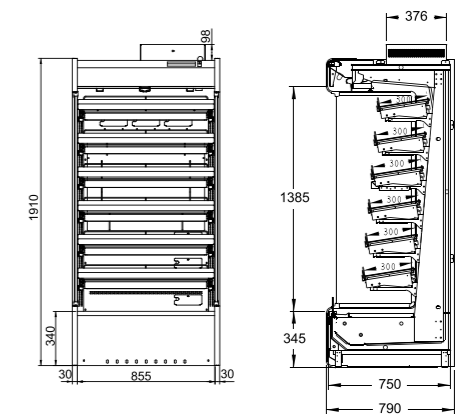

Hot and Cold Remote Lunch Case

Product Parameters

Standard Model	Hot and Cold Lunch Case		
	CLCR855H	CLCR855AH	CLCP855H
Width (mm)	855		915
Depth (mm)	750		
Height (mm)	1910		
Rated Voltage (V)	220		
Rated Frequency (Hz)	50/60		
Refrigeration temperature range (°C)	1-10	-1-5	1-10
Net Weight (kg)	190	226	210
Display Area (m ²)	2.05	1.86	1.85
Effective Volume (m ³)	0.46	0.47	0.39
Energy Efficiency Level (EEL)	2	3	1