

Nimble Series Plug-in Island



BENEFITS AT A GLANCE

- Narrow cabinets to save space for markets
- Automatic defrost, saving time and efforts
- Dual temperature control, switch between MT and LT
- With universal wheels at the bottom, easy to move

CUSTOMER VALUE

- Plug-in island case, plug and play, flexible deployment
- Dual temperature design, switch between MT and LT at will and flexible application



Standard Model	Self-service		
	AIW0.3G	AIW0.4G	AIW0.5G
Dimensions (Width)	1570	2065	2565
Dimensions (Depth)	1065		
Dimensions (Height)	915		
Operation Temperature (°C)	≤ -15/ 0~ 5		
Temperature Grade	3 M1& L1		
Rated Voltage (V)	220V		
Rated Frequency (Hz)	50Hz		
Net Weight (kg)	160	200	260
Display Area (m ²)	1.20	1.58	2.00
Effective Volume (m ³)	0.27	0.29	0.36
Energy Efficiency Level (EEL)	Grade 2		

NOMENCLATURE

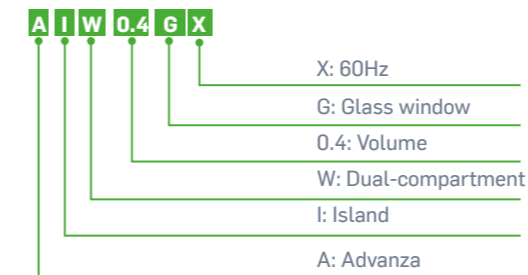

DIMENSION DRAWING

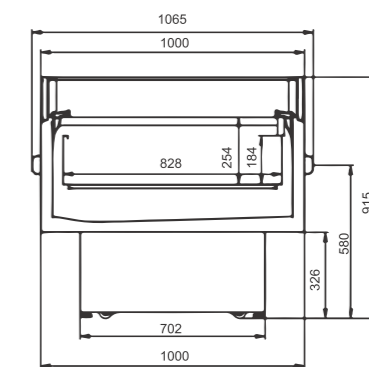

Nimble Series Plug-in Island